





Keytouch IEC 60945 approved Joystick Panel

The Keytouch standardpanel series has been developed to meet the specific need and demand of the maritime market.

The joystick can be a standalone unit or can be utilized with other Keytouch units.

It is a 3-axis joystick and offers functions like put-and-stay with a button on top. Alternative joysticks from the same series with other options can be used.

The Keytouch Joystick panel can be adapted to meet individual OEM customer color, logo and design requirements.

Size (w*h)	Panel: 119 x 188mm Cutout: 94 x 162mm min.
Mounting	Drop-in module with mounting holes in frame.
Protection Level	IP22
Interface	USB type B, windows compatible 
Backlight	No
Operation Temperature	-15°C~ 55°C
Storage Temperature	-20°C~ 60°C
Joystick	CALDARO ZC06B-9241A 3-AXIS, 1 switch
Approvals	Tested and approved according to IEC60945. Complete testreport is available on request. 
Optional	<ul style="list-style-type: none"> - Can/Open - Profi BUS - Field BUS - Device NET - LAN - Up to 5 more analog inputs - Up to 12 swiches or indicators - Other type of joystick available

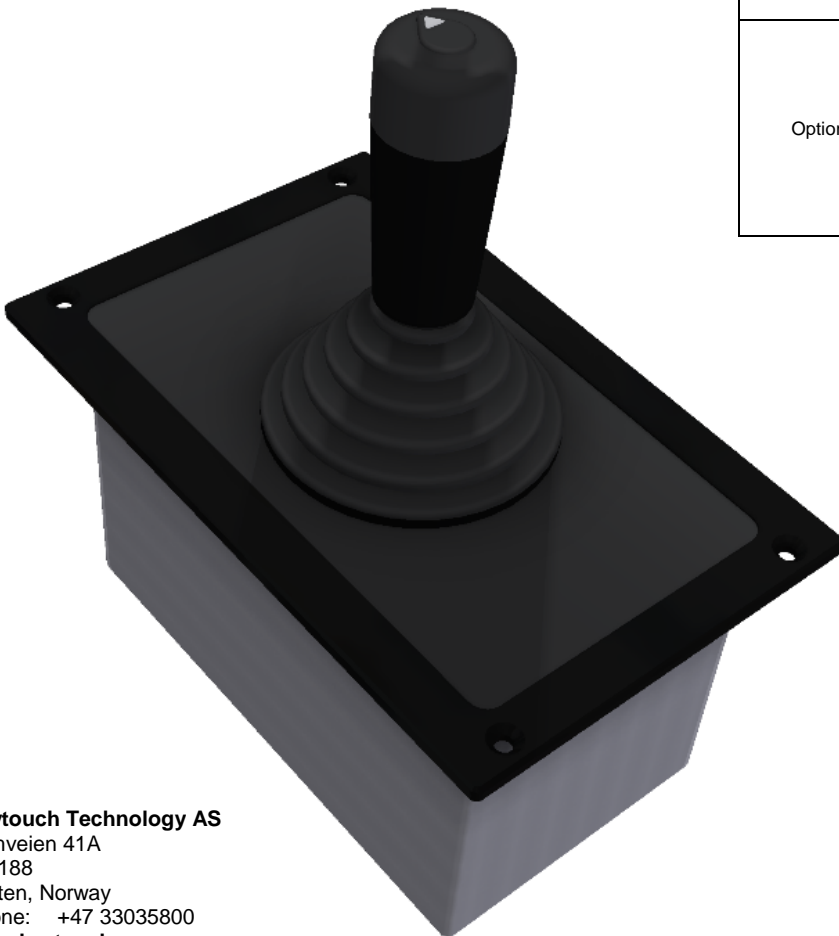

Keytouch Technology AS
Trimveien 41A
N-3188
Horten, Norway
Phone: +47 33035800
www.keytouch.no



Installation

Mechanical

The panel is designed as a drop-in-panel, which requires a cutout in the console and 4x countersunk M4 screws.

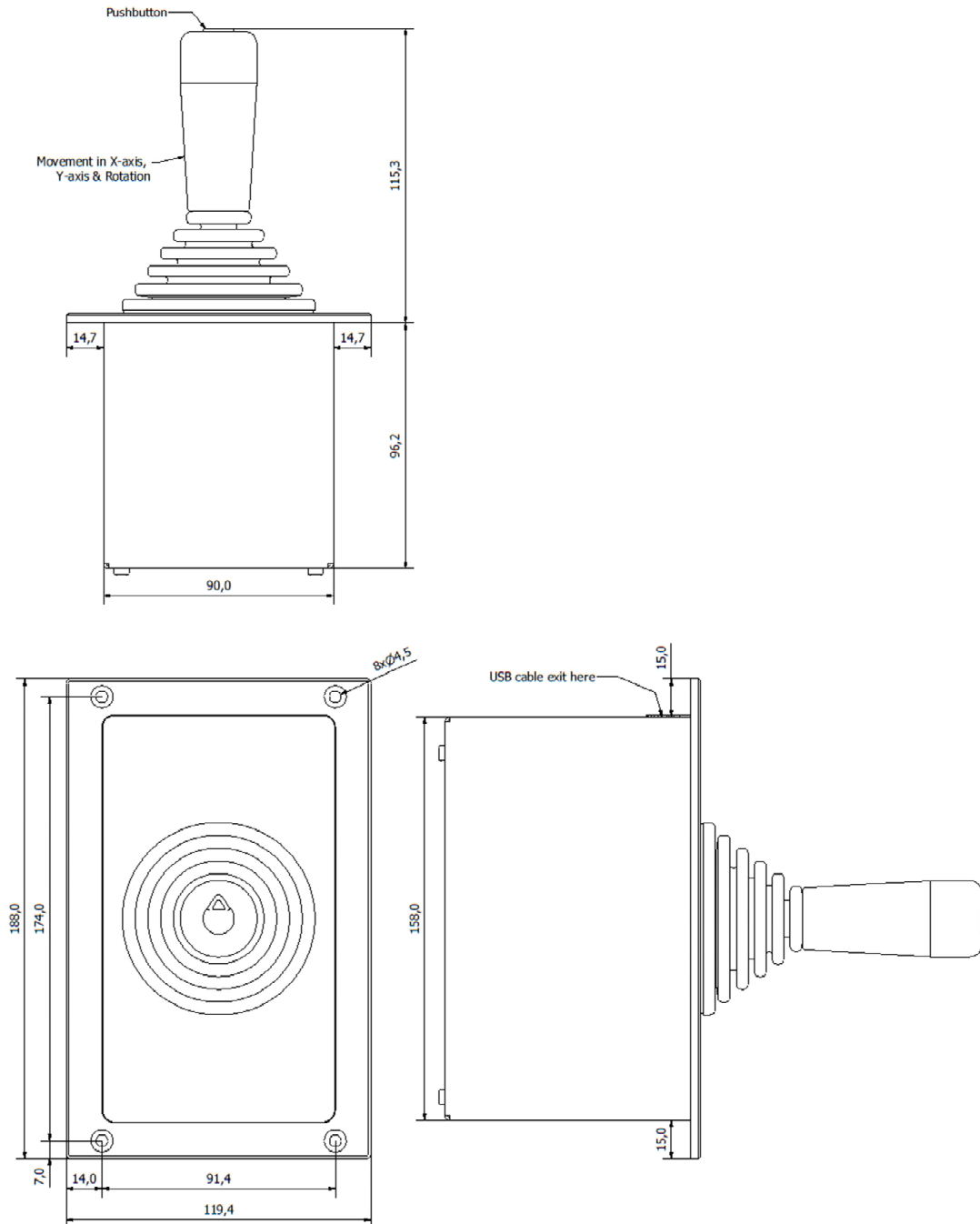

Connections

The panel comes with a cable, USB type A connector.

Device driver

The keyboard and trackball are USB HID interface compatible and there is no need for a special device driver. It will appear in OS as a gaming device.